

MILL TURN CENTER

MT-540



- Siemens ATE AC300/240/8 (15/22kW)
- X/Y/Z servo motors:IFK7101-5
- W/B:IFK7083-5
- NEO milling spindle 12,000 rpm
- Build-in turning spindle 4900 rpm.
- INDRAMAT motor 1MBS162D (29/35KW)
- KM63 36-tool ATC.
- AUTOGRIP 8" chuck
- Draw bar dia.: 65mm
- Programmable tailstock with MT4 Quill
- Coolant system
- Air conditioner on power cabinet
- Automatic lubrication system
- Fully closure splash guarding
- Foot pedal for chuck
- Chain type chip conveyor and chip cart
- Transformer (75 KVA)
- Controller manuals
- 2-year controller warranty
- 1-year machine parts warranty (Ex-work Factory)
- Linear guide way
- Class C2 ballscrews

MT-540

Working range	
Chuck size (inch)	8
Maximum swing (mm)	Ø540
Maximum machining diameter (mm)	Ø350
Maximum machining length (mm)	700
Main spindle	
Speed (rpm)	4900 (Built-in)
Spindle nose	A2-6
Spindle bore dia. / Draw bar dia. (mm)	Ø75 / Ø65
Front bearing inner dia. (mm)	Ø120
Milling head	
Tool shank type (milling/turning)	KM63
Milling spindle speed (rpm)	12000 (Built-in)
Maximum milling spindle torque (N-m)	160
Milling spindle motor output (kW)	29.3 / 35
A-axis (°)	360°/15°
B-axis	
B-axis (°)	±110° / 0.001°
Speed (rpm)	16.7
Repeatability accuracy (sec)	±3
Maximum torque (N-m)	1920
C-axis	
C-axis (°)	360° / 0.001°
Speed (rpm)	120
Maximum torque (N-m)	580
Maximum output (kW)	15 / 22
Feedrate	
X/Y/Z/W-axis rapid traverse (M/min)	36 / 36 / 36 / 30
ATC	
Tool capacity (pcs)	36 (72)
Max. tool length (mm)	200
Max. tool diameter (mm)	80
Max. tool weight (kg)	5
T-T (sec)	5
NC	
Siemens / Fanuc	840D / Fanuc 31i

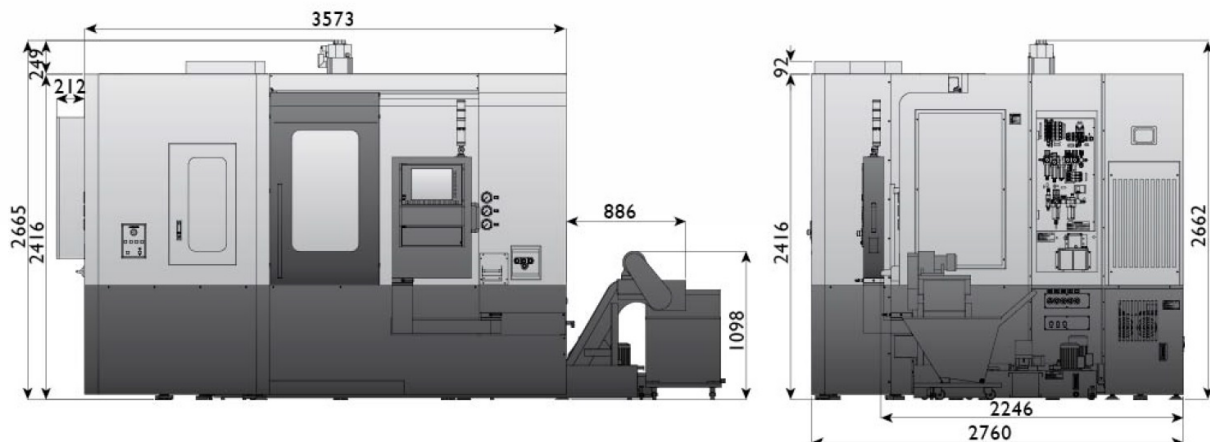

奕達精機股份有限公司 | 41465台中市烏日區溪南路一段357巷68弄41號

YIDA PRECISION MACHINERY CO., LTD. | Tel : 886-4-2335 8368 | Fax: 886-4-2335 6681

No.41, Aly. 68, Ln. 357, Sec. 1, Xinan Rd., Wuri Dist., Taichung City 41465, Taiwan | Email: info@yidacnc.com



TÜV Rheinland certified